

AMF

ADVANCED DOUGH DIVIDER

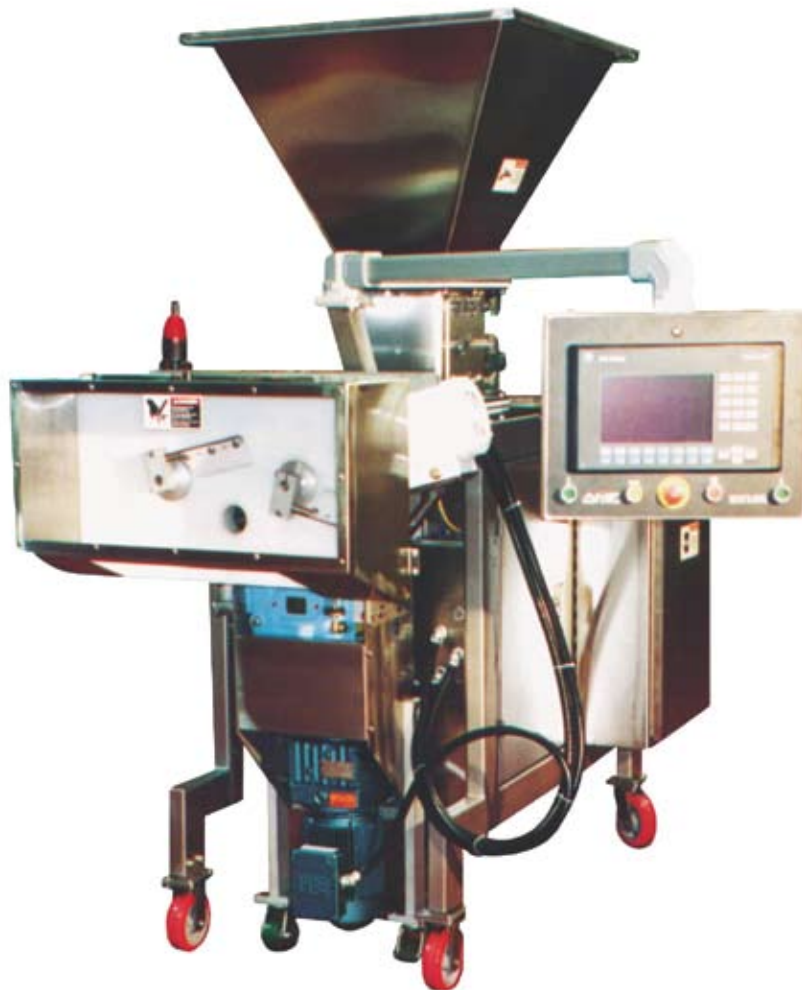

- **The Most Efficient Dough Divider Available for Bread, Pizza and Specialty Doughs**
- **Unmatched Reliability and Scaling Accuracy**
- **High Speed, Up to 20,000 lb. (9072 kg) Per Hour**



ADVANCED DOUGH DIVIDER

FEATURES & BENEFITS

Most Accurate Scaling Available Through Advanced Extrusion Technology

- Increased product yield
- Reduced waste
- Improved product uniformity
- Consistent scaling accuracy over the life of the divider

Reduced Operating Cost

- No divider oil required with the ADD, which reduces operating and sanitation cost
- Efficient design with few moving parts for reduced maintenance cost
- Rotary drive design provides a service life 3-4 times that of conventional dividers

Increased Productivity and Flexibility

- Increased operating speeds up to 300 cuts per minute can increase your hourly production yield
- Wide range of dough piece sizes without downtime for divider modifications
- Long, continuous runs for days at a time without downtime for cleaning or maintenance adjustments can increase profits per unit

Improved Automation

- Operator interface-based recipe management system is provided for automated divider setup and downstream equipment setup

MECHANICAL FEATURES

- Heavy duty stainless steel frame for durability and corrosion resistance
- Polished stainless steel guards and 500 lb. (227 kg) hopper for easy sanitation
- Precision stainless steel tunnel housing for durability and minimum dough flow resistance
- Dual auger design for gentle dough handling at high throughputs
- Class F insulated Eurodrive gearmotors on augers and metering pump for dependability, long life, and 94% mechanical efficiency
- 3" (76 mm) metering pump for precise flow control without back pressure
- UHMW rotary cut-off knife
- Easy access to all operational areas for easy sanitation and maintenance
- Ventura-style vacuum system with vacuum transducer
- Freestanding with casters for easy mobility for sanitation and maintenance
- Stainless steel hopper transition with safety interlocked access door



ELECTRICAL FEATURES

Operator panel is NEMA 4 rated and mounted on a pendant/swivel arm for easy access and includes the following:

- Allen Bradley PanelView Plus operator interface to control:
 - Auger speed
 - Metering pump speed
 - Alarm messages
 - Product codes
 - Knife speed
 - Downstream equipment
- Allen Bradley push buttons for the following functions:
 - Two-button start

- Stop/Emergency stop
- MCR reset

NEMA 12 painted remote electrical enclosure including:

- Main disconnect switch
- System control components
- Cabinet cooler
- Allen Bradley CompactLogix PLC
- Allen Bradley PowerFlex inverters
- Closed-loop pressure control system with pressure transducer

PLC controlled cleaning cycle system for reduced sanitation cost

Vacuum pressure display on operator interface

OPTIONS

- 1600 lb. (726 kg) stainless steel dough hopper
- Teflon hopper lining
- Product memory increase
- Operator interface in lieu of Allen Bradley PanelView Plus
- PLC other than Allen Bradley CompactLogix
- Inverter other than Allen Bradley
- Stainless steel panel in lieu of painted
- Change-out nozzles
- Panel air conditioner in lieu of Exair panel cooler
- Panel modem for remote diagnostics
- CE confirmed electrical package
- Integrated controls for pump and conveyor system
- Spare parts kit
- Additional machine manuals

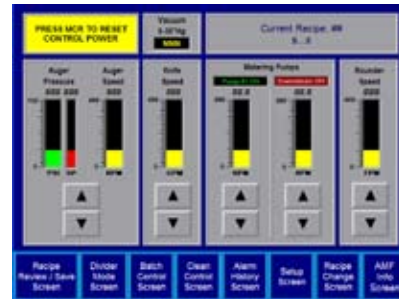

Available Touchscreen Recipe Controls

SPECIFICATIONS

Model	Maximum Throughput	Scaling Range	Speed Range (max. ppm)	Typical Scaling Accuracy	Approximate Shipping Weight
Single Cut-off	20,000 lb./hr. (9072 kg/hr.)	9 oz. - 38 oz. (255 g - 1077 g)	200	+/-1%	4,200 lb. (1905 kg)
Dual Cut-off	20,000 lb./hr. (9072 kg/hr.)	9 oz. - 38 oz. (255 g - 1077 g)	300	+/-1%	4,200 lb. (1905 kg)

Electrical Requirements:

Approximate Main Power

- Single and Dual Cut-off: 39 KVA
- Triple Cut-off: 57 KVA

PLC I/O Voltage: 24VDC in/120VAC out

Air Requirements: 25 SCFM @ 87 PSIG

Water Requirements: 4 to 6 gal./min. at 120° (15 to 23 L/min. at 49°C) (cleaning only)

Approximate Shipping Dimensions:

Single and Dual Cut-Off:

99" x 57" x 80"

(2510 mm x 1448 mm x 2032 mm)

ADVANCED DOUGH DIVIDER

DIMENSIONAL DRAWING

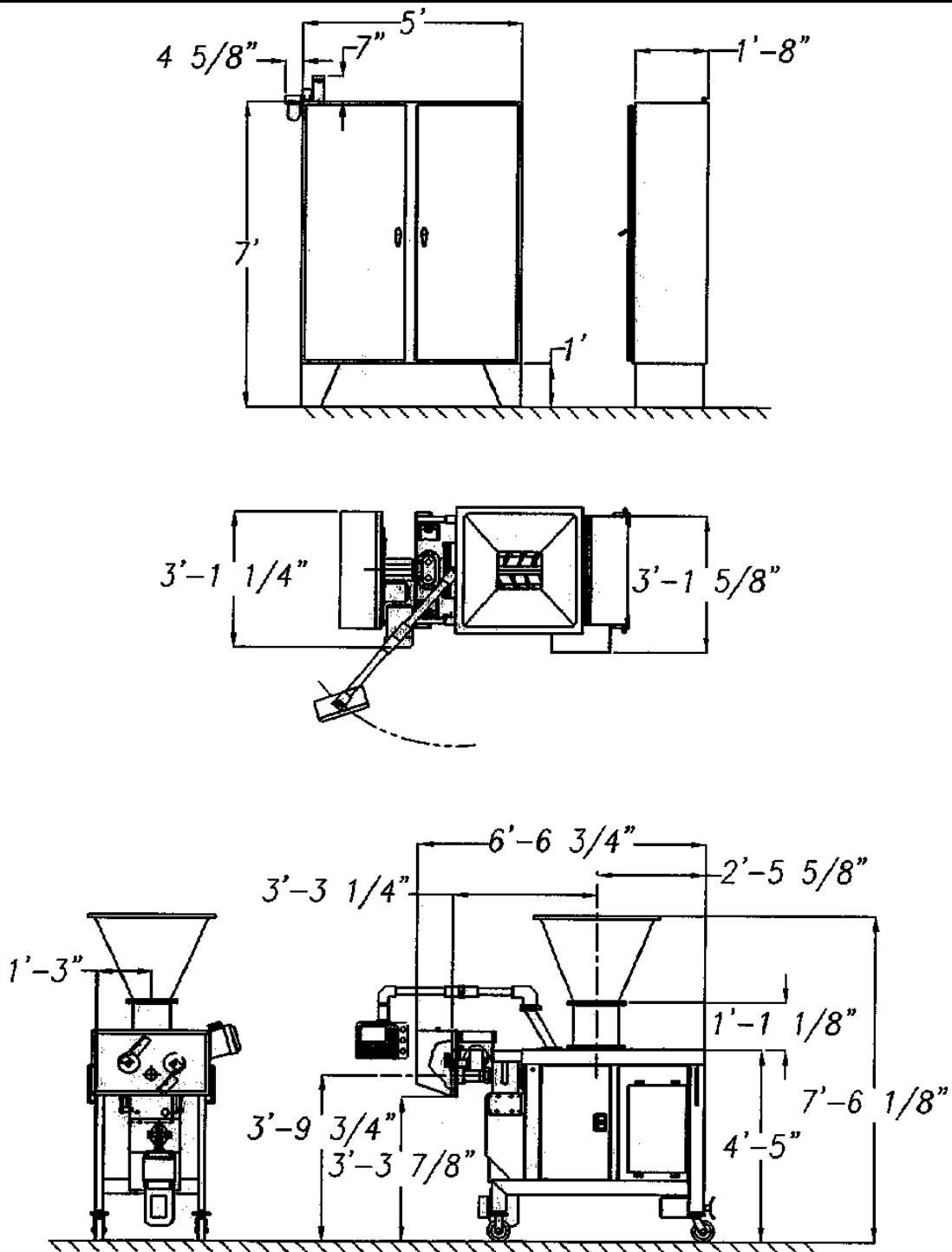

500 lb. (227 kg) hopper shown

Headquarters:

2115 W. Laburnum Ave.
Richmond, Virginia 23227
Tel: 1-800-225-3771
or 1-804-355-7961
Fax: 1-804-342-9724
sales@amfbakery.com

Europe Office:

West Park Ring Road
Leeds LS16 6QQ
England
Tel: 44-1132-787110
Fax: 44-1132-741415
sales-europe@amfbakery.com

Asia Office:

Room 15-2, A-Building
Thunis Dev. Building
No.11 Hui Xin East St.
Chaoyang District
Beijing, China 100029
Tel: 86-10-64823613
Fax: 86-10-64934259
sales-asia@amfbakery.com

FOR MORE INFORMATION PLEASE CALL YOUR ACCOUNT MANAGER OR

1-800-BAKERS-1
www.amfbakery.com

AMF's focus on continuous improvement may result in changes to machinery specifications without notice.