

AMF

DOUGH BALL SPACER



- **Designed to Properly Space Dough Balls Prior to Entering the Sheeting Rollers**
- **Virtually Eliminates Doubles**

DOUGH BALL SPACER

FEATURES & BENEFITS

- 1) Side plate, aluminum construction frame
- 2) Side covers are 7" wide (178 mm) for easier maintenance
- 3) Stainless steel tapered dough guide with UHMW comb-type guide to fit roller in order to stop the dough from getting behind the dough guide
- 4) Wider shaft in order to get space in between the side frame and roller
- 5) Sprocket and chains are #40 regular
- 6) Chain binders on each side
- 7) Adjustable front roller on sealed bearings with protected plate
- 8) All shafts are mounted on sealed bearings and locked on with set screws
- 9) Motor 1/2 HP and reducer (ratio 5 to 1) - optional AC inverter
(All rollers are of different speeds to equalize flow of dough piece to moulders)

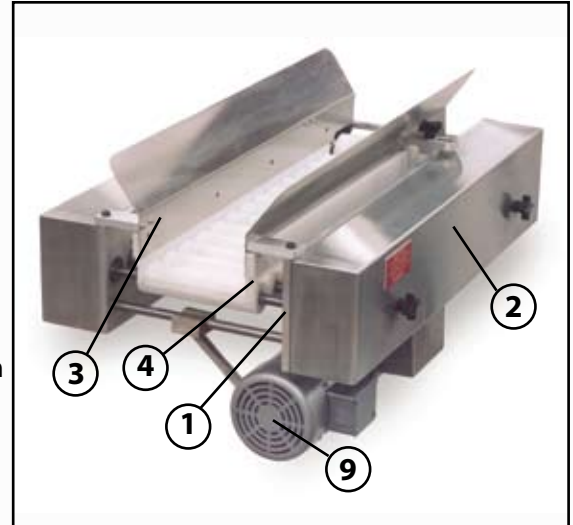

DIMENSIONAL DRAWING

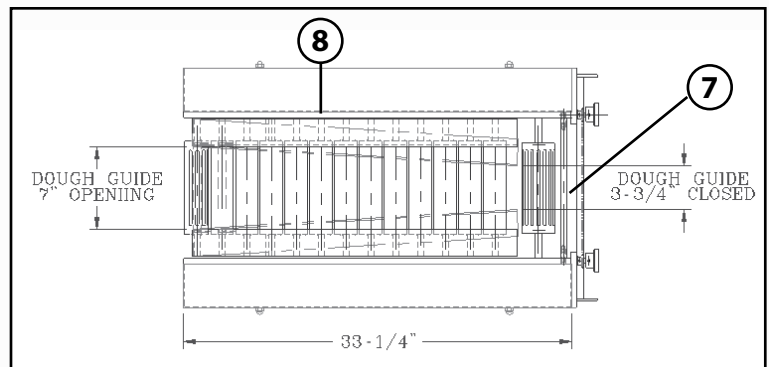
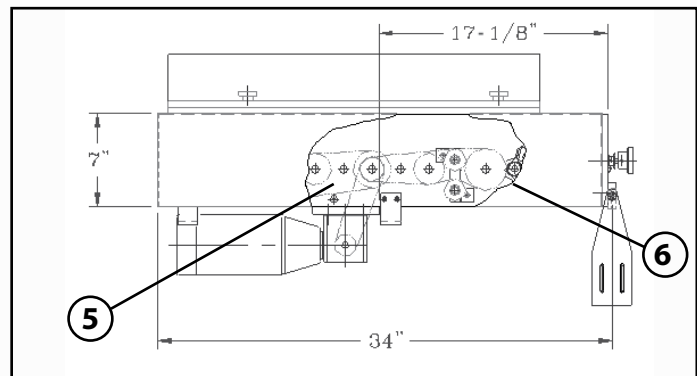
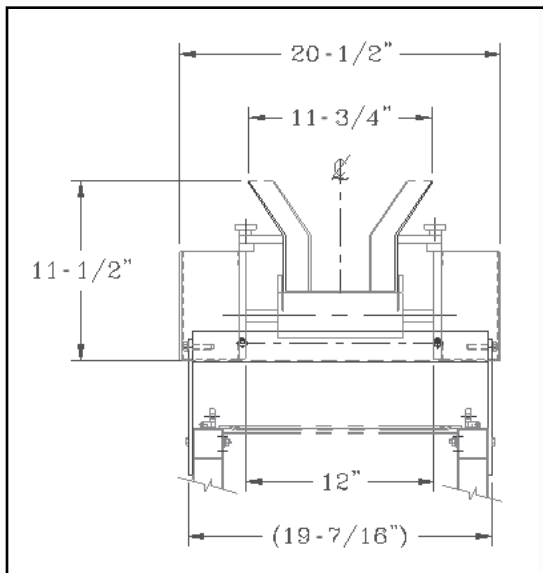

Headquarters:
2115 W. Laburnum Ave.
Richmond, Virginia 23227
Tel: 1-800-225-3771
or 1-804-355-7961
Fax: 1-804-342-9724
sales@amfbakery.com

Europe Office:
West Park Ring Road
Leeds LS16 6QQ
England
Tel: 44-1132-787110
Fax: 44-1132-741415
sales-europe@amfbakery.com

Asia Office:
Room 15-2, A-Building
Thunis Dev. Building
No.11 Hui Xin East St.
Chaoyang District
Beijing, China 100029
Tel: 86-10-64823613
Fax: 86-10-64934259
sales-asia@amfbakery.com

FOR MORE INFORMATION PLEASE CALL YOUR ACCOUNT MANAGER OR

1-800-BAKERS-1
www.amfbakery.com