

AMF

DOUGH TROUGH HOIST



- **Vertical or Slant Legs**
- **Ceiling or Free Standing Support Options**
- **Variety of Chute and Gate Options**
- **Custom Design for Special Applications**

FEATURES & BENEFITS

- The trough hoist is available in either vertical or slant leg type. The complete hoist is fabricated from heavy gauge steel plate. Lift chains are mounted inside the legs and driven by sprockets welded to the top main shaft and secured to the hoist legs via special heavy duty roller bearings.
- To ensure adequate static and shock load capacities, uses #120 chain having 34,000 pound tensile strength. This provides the hoist with a 20:1 safety factor.
- For added safety and simplicity, the gearbox is mounted directly onto the main shaft and is protected by a torque limiter, which will turn the motor off in case of overloading.
- To provide additional safety, the hoist is equipped with special safety latches that prevent the cradle and trough from falling in the unlikely event of chain breakage.
- The cradle is custom built to suit your specific trough requirements.
- Hoist is supplied with stationary chute. Chutes are designed and built to accommodate all types of mixers or dividers.
- New 3 HP SEW Eurodrive unit (TEFC)
- All electrical wiring is NEMA 12 in waterproof conduits with Allen Bradley controls.
- Steel-it exterior finish



Safety Latch Engaged

OPTIONS

- Chute tilting kit
- Stainless steel legs - 5' (1524 mm) or full length
- Stainless steel cradle in lieu of mild steel
- Free standing structure (mild or stainless steel)
- Water spray manifold
- Special cradle for two different heights of dough trough
- Nord Gear drive unit 3 HP
- Gate options
- Guillotine cutter option

DIMENSIONAL DRAWING

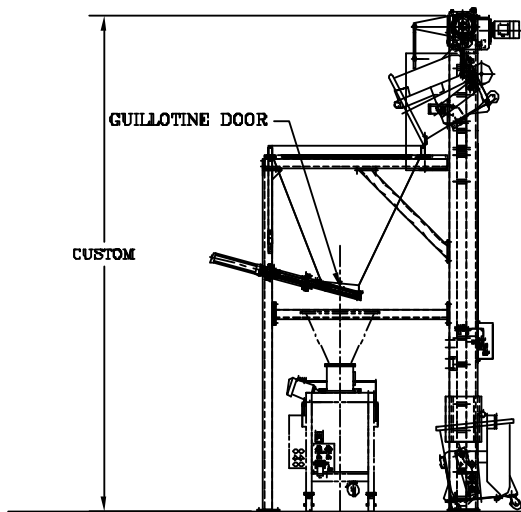

TROUGH HOIST-DIVIDER

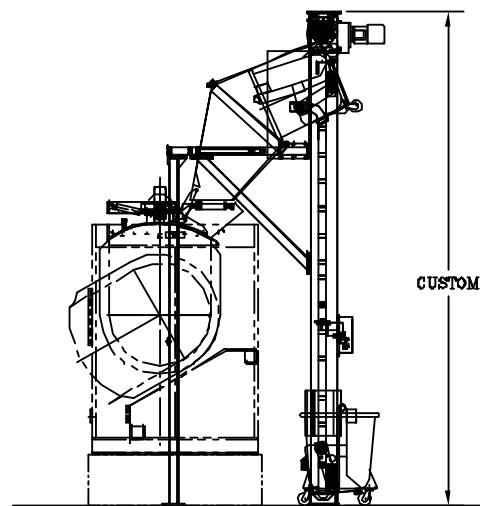

TROUGH HOIST-MIXER

Headquarters:
2115 W. Laburnum Ave.
Richmond, Virginia 23227
Tel: 1-800-225-3771
or 1-804-355-7961
Fax: 1-804-342-9724
sales@amfbakery.com

Europe Office:
6 The Sidings
Station Road, Guiseley
Leeds LS20 8BX, England
Tel: 44-1943-875703
Fax: 44-1943-871806
sales-europe@amfbakery.com

Asia Office:
Room 15-2, A-Building
Thunis Dev. Building
No.11 Hui Xin East St.
Chaoyang District
Beijing, China 100029
Tel: 86-10-64823613
Fax: 86-10-64934259
sales-asia@amfbakery.com

FOR MORE INFORMATION PLEASE CALL YOUR ACCOUNT MANAGER OR

1-800-BAKERS-1
www.amfbakery.com

AMF's focus on continuous improvement may result in changes to machinery specifications without notice.