

AMF

MAGNETIC PAN STACKER OR UNSTACKER



- **The Magnetic Head Pan Stacker or Unstacker is State-of-the-Art for High Speed Stacking or Unstacking of Bread and/or Bun Pans**
- **Standard Automatic Pan Truck Loading Dock**
- **Available with Semi-Automatic or Fully Automatic Pan Adjustment Controls**
- **Combination Stacker/Recycling/Unstacker Unit is Available for Use with Lids**

MAGNETIC PAN STACKER OR UNSTACKER

FEATURES & BENEFITS

- Heavy-duty construction and quality components assure high performance, operation longevity and low maintenance
- Highly versatile design allows several plan flow configurations to meet different production and layout requirements
- Allows for pan recycling through the unit
- Combination stacking/unstacking in the same unit is possible for lid operations
- Use of electromagnets on the ram system allows for added flexibility of adjustable magnetic force for different pan and lid designs
- Crank arm design with acceleration/deceleration curves allows for gentle pan handling and reduced noise
- Semi-automatic set-up via an operator interface reduces operator error

MECHANICAL FEATURES

- Smooth pan handling via variable speed and spring dampened magnetic ram motion with eccentric movement
- Use of pneumatic clutch and brake on motors with frequent start/stop
- Standard design for use of "U" shape pan truck - custom design available to fit other pan handling system
- Standard 6' (1829 mm) metering conveyor is supplied with a stacker unit



Metering Conveyor and Double Magnetic Belt



Pneumatic Cabinet



Main Carriage Drive

ELECTRICAL FEATURES

Operator panel is painted NEMA 12 rated and contains the following:

- Allen Bradley PanelView 1000 operator interface which displays:
 - Machine start and stop
 - Operation speed
 - Status, alarm and history messages
- Allen Bradley push buttons for the following functions:
 - Alarm acknowledge/reset
 - MCR reset
 - Emergency stop

NEMA 12 enclosure (painted steel) including:

- Main power disconnect
- Allen Bradley SLC 5/03 programmable logic controller
- Allen Bradley AC inverter for main drive



Standard Electrical Panel



Operator Interface

MECHANICAL OPTIONS

- "U" shaped pan trucks, painted steel construction
- "U" shaped pan trucks, hot dipped galvanized steel construction
- Auxiliary stack lift is available when there is not enough accumulation in pan conveyors for stack changes (recommended on bread and bun combination unit or on high pan rate application)



"U" Shaped Pan Truck

ELECTRICAL OPTIONS

- Allen Bradley PV1000 operator interface in lieu of standard
- Allen Bradley SLC 5/04 PLC in lieu of standard
- Fully automatic pan adjustment via recipe selection
- Stainless steel electrical enclosure

SPECIFICATIONS

Rate:

40/minute depending on pan size

Stack Height:

60" (1524 mm) maximum bread pans

40" (1016 mm) maximum bun pans

Pan Size:

Height: $\frac{3}{4}$ " to 6" (19 mm to 152 mm)

Width: 8" to 36" (203 mm to 914 mm)

Length: 24" to 36" (610 mm to 914 mm)

(If pan width or length exceeds 36" (914 mm), please consult AMF Engineering)

Electrical Requirements:

15 KVA

230/460 volts/3 phases/60 Hz

PLC I/O Voltage: 24VDC in/120VAC out

Air Requirements: 1 SCFM

Approximate Dimensions:

With Head Installed: 120" L x 84" W x 132" H
(3048 mm x 2134 mm x 3353 mm)

With Head Removed: 84" L x 96" W x 96" H
(2134 mm x 2438 mm x 2438 mm)

Approximate Shipping Weight:

Head: 1,500 lb. (680 kg)

Body: 2,200 lb. (998 kg)

Truck Dock Conveyor: 800 lb. (363 kg)

MAGNETIC PAN STACKER OR UNSTACKER

DIMENSIONAL DRAWING

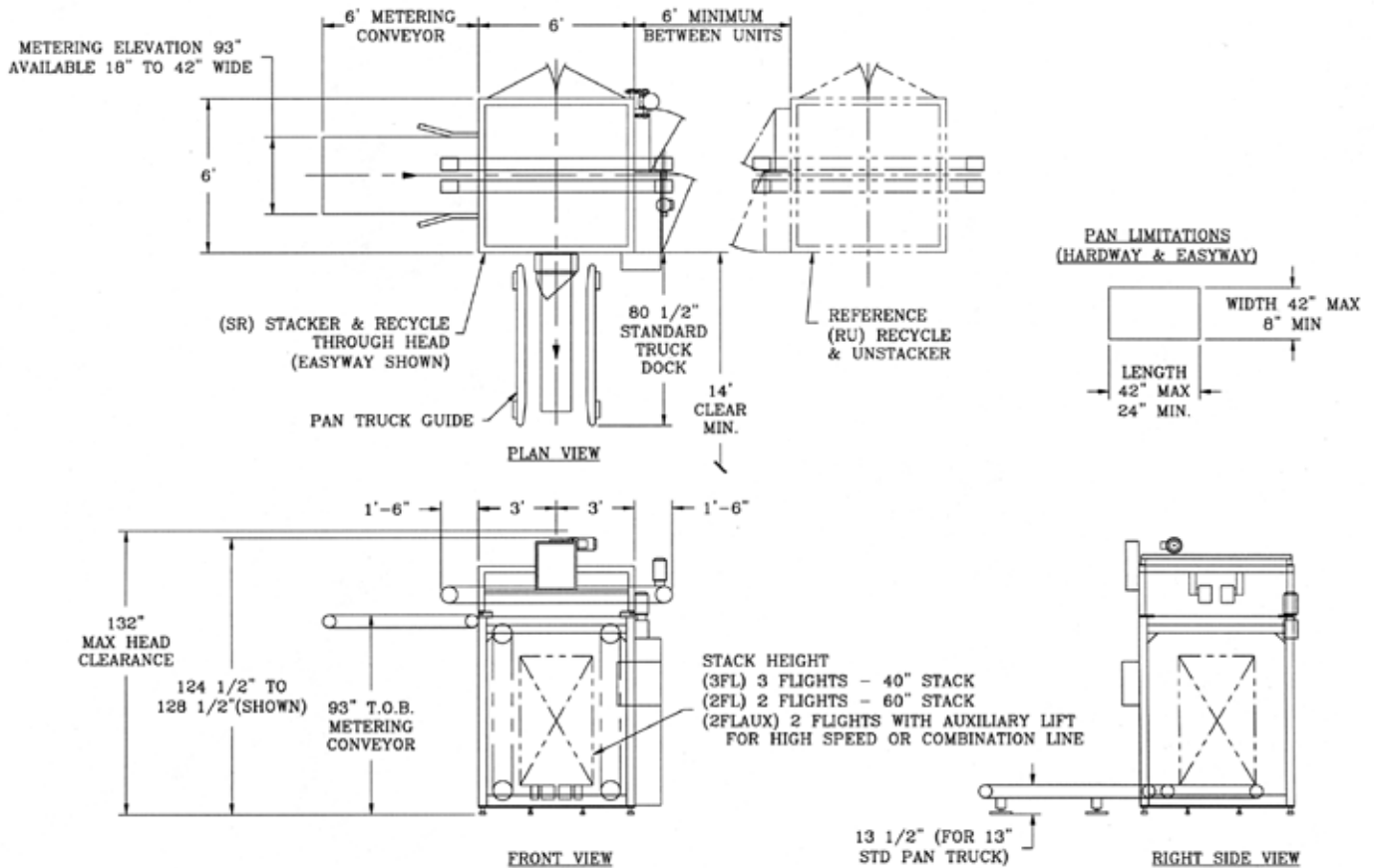

HEAD CONVEYOR FLOW OPTION PLAN VIEW

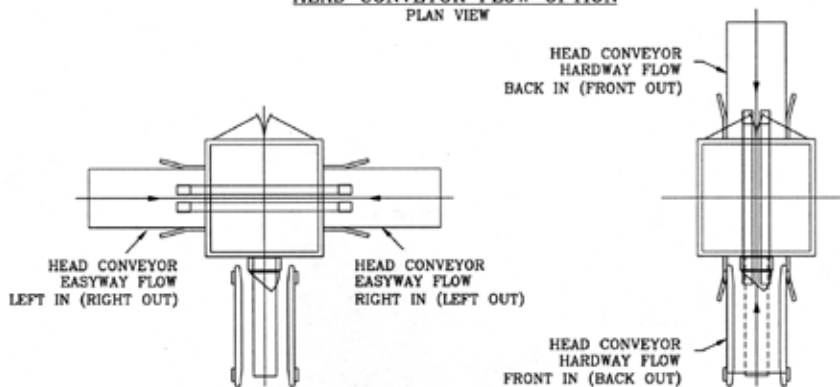

CONTROLS & DRIVE FRONT VIEW

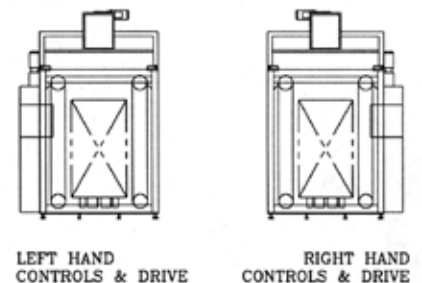

Headquarters:
2115 W. Laburnum Ave.
Richmond, Virginia 23227
Tel: 1-800-225-3771
or 1-804-355-7961
Fax: 1-804-342-9724
sales@amfbakery.com

Europe Office:
6 The Sidings
Station Road, Guiseley
Leeds LS20 8BX, England
Tel: 44-1943-875703
Fax: 44-1943-871806
sales-europe@amfbakery.com

Asia Office:
2102B, B-Bldg.
No.3 Estate Mansion
No.1 Shuguangxili Rd.
Beijing, China 100028
Tel: 010-58222949
Fax: 010-58222952
sales-asia@amfbakery.com

FOR MORE INFORMATION PLEASE CALL YOUR ACCOUNT MANAGER OR

1-800-BAKERS-1
www.amfbakery.com

AMF's focus on continuous improvement may result in changes to machinery specifications without notice.