

AMF

TORTILLA DIVIDER AND ROUNDER



- **Extrusion Technology Reduces Maintenance and Improves Performance**
- **Higher Speeds Allow Full Utilization of Multiple Press or Sheeting Units**



TORTILLA DIVIDER AND ROUNDER

FEATURES & BENEFITS

Low Maintenance Rotary Divider Design

- Extrusion divider systems features rotary-designed mechanisms for continuous, smooth operation
- Eliminates stop-and-go stroke motion wear of conventional piston dividers
- Highly efficient electric gearmotors eliminate the maintenance and sanitation issues of hydraulic drive systems

Belt Rounding for Continuous Operation

- Belt rounding system utilizes a patented concave rounder bar to round reach dough piece as it travels down the rounder belt in a smooth, non-stop motion
- Eliminates the need for spreader belts and dusting flour
- Reduces changeover time and maintenance

Divide and Round without Divider Oil or Dusting Flour

- Extrusion design requires no divider oil
- Unique belt rounding system requires no dusting flour
- PLC controlled cleaning system reduces operating and sanitation costs and provides a cleaner, healthier operating environment

Superior Operating Performance

- Unmatched scaling accuracy (+/- 1% is typical)
- Offers long, continuous runs with no downtime needed for maintenance

MECHANICAL FEATURES

- Durable stainless steel frame
- Stainless steel guards and 500 lb. (227 kg) hopper for easy sanitation
- Precision stainless steel tunnel housing for longevity and sanitation
- Dual auger design for gentle dough handling
- All drives are high-efficiency Class F insulated Eurodrive gearmotors with AC speed control including augers, metering pump, cut-off knife, rounder belt and proofer drive
- 3" (76 mm) metering pump for precise flow control with less pressure
- Patented UHMW free-flow manifold for even dough distribution
- UHMW rotary cut-off knife
- Venturi-style vacuum system with vacuum transducer
- Poly slick rounder belt to prevent sticking
- UHMW concave rounder bars with a patented floating foot to produce round dough pieces without dough leakage
- Hinged rounder bar frame with gas spring assist for easy cleaning and maintenance access
- Cantilevered rounder frame design for quick belt changes
- Independently controlled UHMW kicker roller for precise dough ball transfer control

ELECTRICAL FEATURES

Operator panel is NEMA 4 rated and mounted on a swivel arm for easy access

Operator panel includes:

- Allen Bradley 600C keypad operator interface to control:
 - Auger pressure
 - Metering pump speed
 - Vacuum level
 - Alarm messages and product codes
 - Rounder belt speed
- Allen Bradley push buttons for:
 - Two button start
 - Stop and emergency stop
 - MCR reset

NEMA 12 painted remote electrical enclosure including:

- Main disconnect switch
- Full voltage magnetic NEMA rated starters
- Allen Bradley 5/03 PLC
- Toshiba inverters

Schmersal key safety switches

Closed loop pressure control system with pressure transducer

PLC controlled cleaning system for reduced sanitation cost

Electronic proofer synchronization kit with proofer drive



OPTIONS

Mechanical Options

- Automatic divider pushback
- 300 lb. (136 kg) stainless steel hopper in lieu of 500 lb. (227 kg)
- Chilled rounder bed option
- Additional machine manuals
- Spare parts kit

Electrical Options

- Allen Bradley 5/04 PLC upgrade
- Stainless steel electrical panel in lieu of painted
- Panel air conditioner in lieu of Exair panel cooler
- Panel modem for diagnostics
- CE electrical package
- Operator interface in lieu of Allen Bradley PanelView 600C
- Product memory increase

SPECIFICATIONS

	Maximum Throughput*	Scaling Range*	Speed Range (pcs./hr.)	Approximate Shipping Weight
4 Across	6,750 lb./hr. (3062 kg/hr.)	7/8-10 oz. (25-284 g)	3,600-24,000	6,850 lb. (3107 kg)
6 Across	9,900 lb./hr. (4491 kg/hr.)	7/8-10 oz. (25-284 g)	5,400-36,000	6,950 lb. (3153 kg)
8 Across	13,500 lb./hr. (6124 kg/hr.)	7/8-10 oz. (25-284 g)	7,200-48,000	7,050 lb. (3198 kg)
9 Across	15,000 lb./hr. (6804 kg/hr.)	7/8-10 oz. (25-284 g)	8,100-54,000	7,150 lb. (3243 kg)

*Throughput, maximum speed and scaling range are dependent on several factors including dough condition, product configuration and other associated equipment. Gearmotors are sized to meet a specific production range.

Electrical Requirements:

Main Power: 23 KVA

PLC I/O Voltage: 24VDC in/120VAC out

Air Requirements: 25 SCFM @ 87 PSIG

Water Requirements: 4 to 6 gal. (15 to 23 L)/min. at 120° F (49° C) - cleaning only

Approximate Shipping Dimensions:

99" L x 57" W x 80" H

(2515 mm x 1448 mm x 2032 mm)

TORTILLA DIVIDER AND ROUNDER

DIMENSIONAL DRAWING

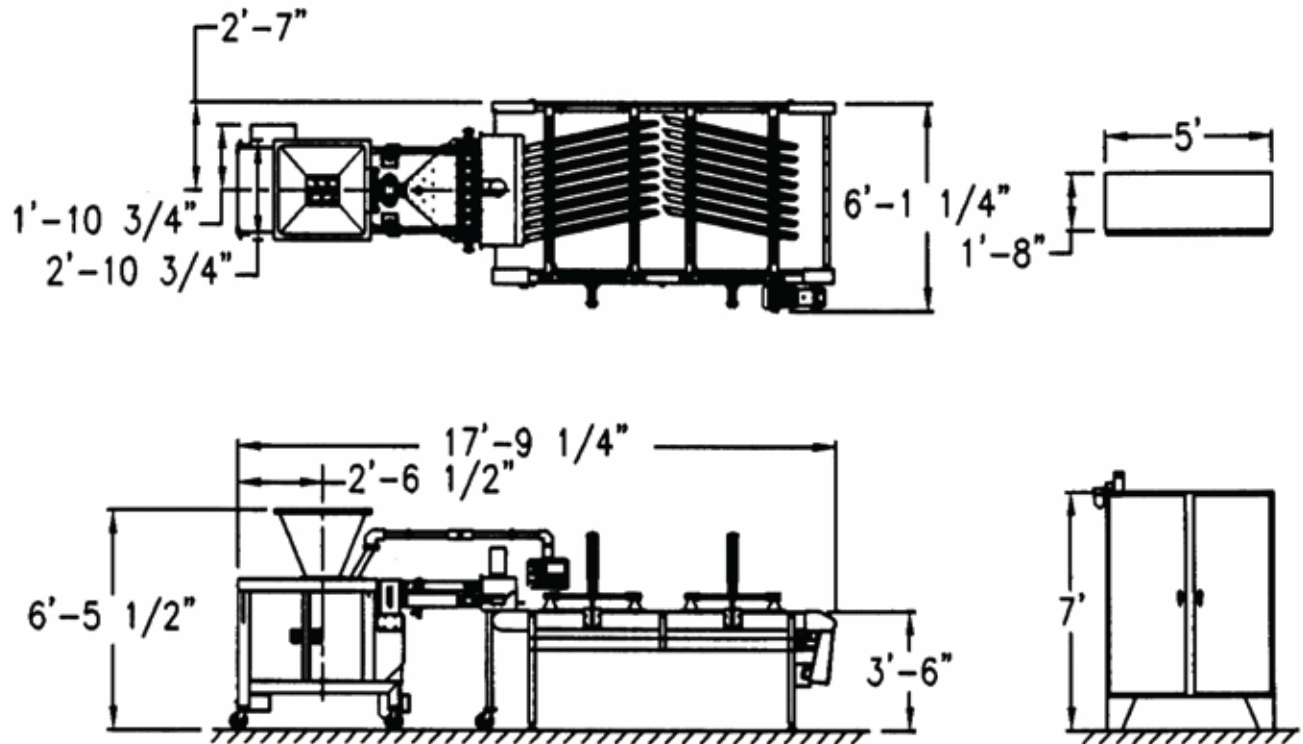

Headquarters:

2115 W. Laburnum Ave.
Richmond, Virginia 23227
Tel: 1-800-225-3771
or 1-804-355-7961
Fax: 1-804-342-9724
sales@amfbakery.com

Europe Office:

West Park Ring Road
Leeds LS16 6QQ
England
Tel: 44-1132-787110
Fax: 44-1132-741415
sales-europe@amfbakery.com

Asia Office:

Room 15-2, A-Building
Thunis Dev. Building
No.11 Hui Xin East St.
Chaoyang District
Beijing, China 100029
Tel: 86-10-64823613
Fax: 86-10-64934259
sales-asia@amfbakery.com

FOR MORE INFORMATION PLEASE CALL YOUR ACCOUNT MANAGER OR

1-800-BAKERS-1
www.amfbakery.com

AMF's focus on continuous improvement may result in changes to machinery specifications without notice.